

SINGER
990B3,B5

Parts List

SINGER

Parts List for 990B3 Machine

Ref. No.	Part No. For Ordering	Description	Amt. Req.
1	(107031) 115699	Machine Frame Rotary Shaft with Looper (left and right hand) and Needle Driving Shafts Crank Connections. Note: The major components of this mechanism are selectively mated. Therefore only a complete replacement mechanism will be supplied from Clydebank Factory should any of the major components become damaged. However the Needle Driving Shaft Crank Clamping Screw No. 114091, the Looper Shafts Crank Clamping Screws No. 114092, the Crank Connections Cap Screws (Upper) No. 171 (830), Crank Connections Cap Screws (Lower) No. 140159 (830) and the Rotary Shaft Oil Metering Pin No. 107037 can be supplied and fitted as replacements without disturbing the selective mating of the major components.	
2	106477	Looper (left hand) Driving Shaft Bushing (back)	
3	106475	Looper (left hand) Driving Shaft	
4	164053	Looper (left hand) Driving Shaft Thrust Washer	
5	106478	Looper (left hand) Driving Shaft Bushing (front)	
6	106473	Looper (left hand)	
7	164046	Looper (left hand) Carrier with 460 (830) and 50379 (806)	
8	50379 (806)	Looper (left hand) Set Screw	
9	164202	Looper (left hand) Stop Pin	
10	460 (830)	Looper (left hand) Carrier Set Screw	
	1324 (803)	Looper (left hand) Carrier Screw	
	59456	Looper (left hand) Carrier Washer	
	164660	Looper (left hand) Carrier Holder with 1083 (803)	
	114256 (1083)(803)	Looper (left hand) Carrier Holder Clamping Screw	
	164661	Looper (left hand) Carrier Holder 164660 with 1324 (803), 59456 and 164046	
	106477	Looper (right hand) Driving Shaft Bushing (back)	
	106491	Looper (right hand) Driving Shaft	
3	164053	Looper (right hand) Driving Shaft Crank Thrust Washer	
19	106492	Looper (right hand) Driving Shaft Bushing (front)	
20	87027	Looper (right hand)	
21	101970	Looper (right hand) Position Collar	
22	164068	Looper (right hand) Lock Screw Stud	
23	1700 (809)	Looper (right hand) Lock Screw Stud Nut	
24	109927 (869)	Looper (right hand) Carrier Connecting Link Hinge Pin Set Screw	2
25	106495	Looper (right hand) Four-Bar Linkage Mechanism Note: The major components of this mechanism are selectively mated. Therefore only a complete replacement mechanism will be supplied from Clydebank Factory should any of the major components become damaged.	
26	114256 1083 (803)	Looper (right hand) Driving Lever Clamping Screw	
27	114075	Looper (right hand) Carrier Connecting Link Adjusting Sleeve Cap Screw (back)	
28	109795 (803)	Looper (right hand) Carrier Connecting Link Adjusting Screw (front)	
29	106494	Looper (right hand) Driving Shaft Oil Wick	
30	106496	Looper (right hand) Four-Bar Linkage Mechanism Stabiliser	
31	106498	Looper (right hand) Four-Bar Linkage Mechanism Stabiliser Support Bracket	
32	350680	Looper (right hand) Four-Bar Linkage Mechanism Stabiliser Screw	2
33	114036	Looper (right hand) Four-Bar Linkage Mechanism Stabiliser Securing Screw	2
34	106497	Looper (right hand) Four-Bar Linkage Mechanism Stabiliser 106496 with 106498 and two 350680	
35	108117	Machine Frame Rotary Shaft Plug Sleeve	

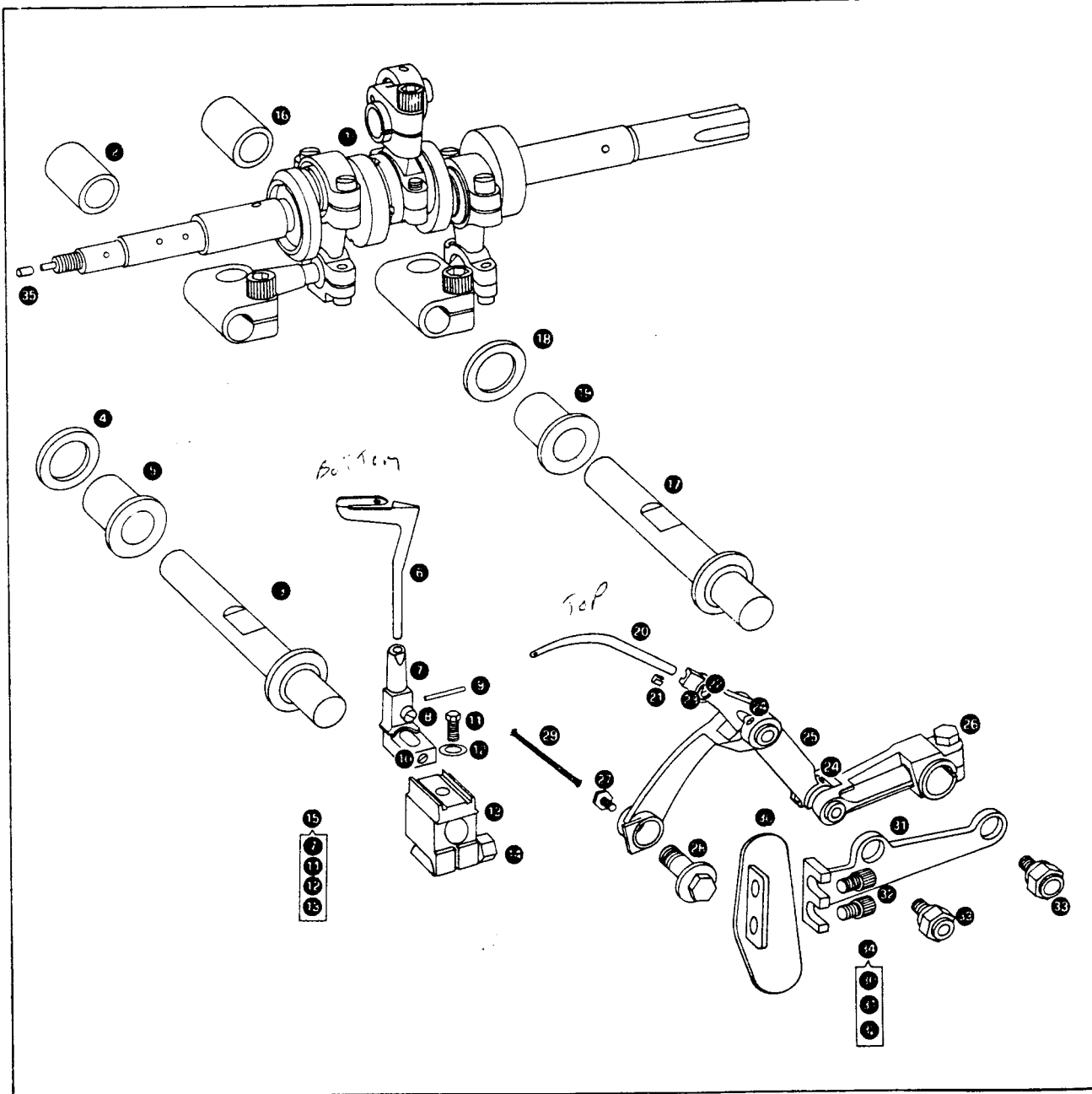
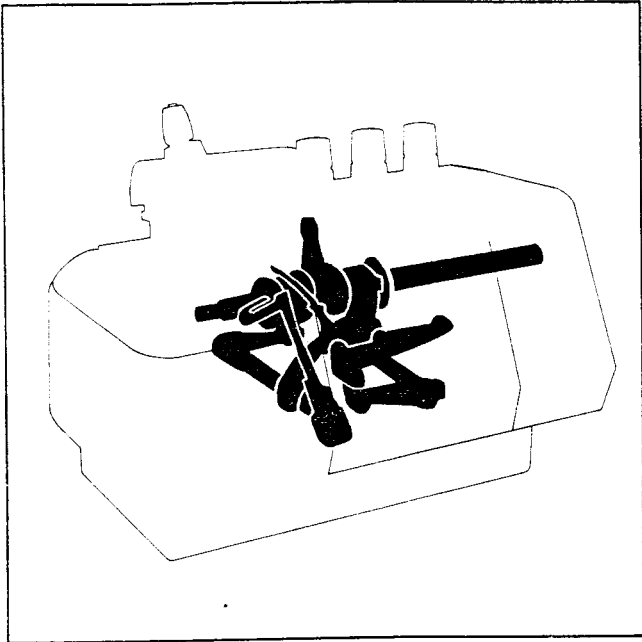

Parts List for 990B3 Machine

Ref. No.	Part No. For Ordering	Description	Amt. Req.
1	1231 (818)	Machine Frame Oil Splash Guard (top) Screw	2
2	107176	Machine Frame Oil Splash Guard (top)	
3	1209 (830)	Feed Bar Guide Screw	2
4	175032	Feed Bar Guide Screw Washer	2
5	107115	Feed Bar Guide	
6	1443 (813)	Feed Eccentric Oil Cover Screw	
7	81202	Feed Eccentric Oil Cover	
8	140346 (830)	Machine Frame Oil Plug Bracket Set Screw	
9	107028	Machine Frame Oil Plug Bracket	
10	1389 (830)	Feed Bar Hinge Pin Set Screw	
11	107162	Feed Bar Hinge Pin (eccentric)	
12	1718 (803)	Feed (front) Bar Connection Hinge Screw Stud Nut	
13	9525	Feed (front) Bar Connection Hinge Screw Stud Nut Washer	
14	107160	Feed (front) Bar Connection Bearing	
15	106447	Feed (front) Bar Connection	
16	164004	Feed Bar Slide Block (back)	2
17	164687	Feed (back) Bar	
18	164009	Feed (back) Bar Connection Hinge Screw Stud	
19	164010	Feed (back) Bar Connection Hinge Screw Stud Position Pin	
20	1454 (806)	Feed (back) Dog Screw	
21	106444	Feed (back) Dog	
22	113177	Machine Frame Rotary Shaft Nut	
23	106445-014	Feed (back) Eccentric (14 stitches to the inch) Note: Eccentrics for 6 to 36 stitches per inch are available as alternatives.	
24	1718 (803)	Feed (back) Bar Connection Hinge Screw Stud Nut	
25	9525 (803)	Feed (back) Bar Connection Hinge Screw Stud Nut Washer	
26	106442	Feed (back) Bar Connection	
27	164018	Feed (back) Bar Connection Bearing	
28	106445-014	Feed (front) Eccentric Note: Eccentrics for 6 to 36 stitches per inch are available as alternatives.	
29	164006	Feed (front) Bar	
30	164009	Feed (front) Bar Connection Hinge Screw Stud	
31	164010	Feed (front) Bar Connection Hinge Screw Stud Position Pin	
32	1454 (809)	Feed (front) Dog Screw	
33	164019	Feed (front) Dog	
34	165135	Feed Bar Slide Block (front)	
35	106448	Feed (back) and (front) Bars complete, Nos. 106442, 106447, 107160, 164006, 164018, 164687, 165135, two each 1718 (803), 9525 (803), 164004 and 164009	
36	51369	Feed Eccentric Cover Hinge Bracket Screw	2
37	106450	Feed Eccentric Cover Hinge Bracket	
38	114071	Feed Eccentric Cover Hinge Screw	
39	106449	Feed Eccentric Cover	
40	107172	Feed Eccentric Cover Latch Spring	
41	227 (809)	Feed Eccentric Cover Latch Spring Screw	
42	1250	Feed Eccentric Cover Latch Spring Retaining Screw Stud	
43	1700 (819)	Feed Eccentric Cover Positioning Screw Lock Nut	
44	141575	Feed Eccentric Cover Positioning Screw	
45	107185	Feed Lifting Eccentric	

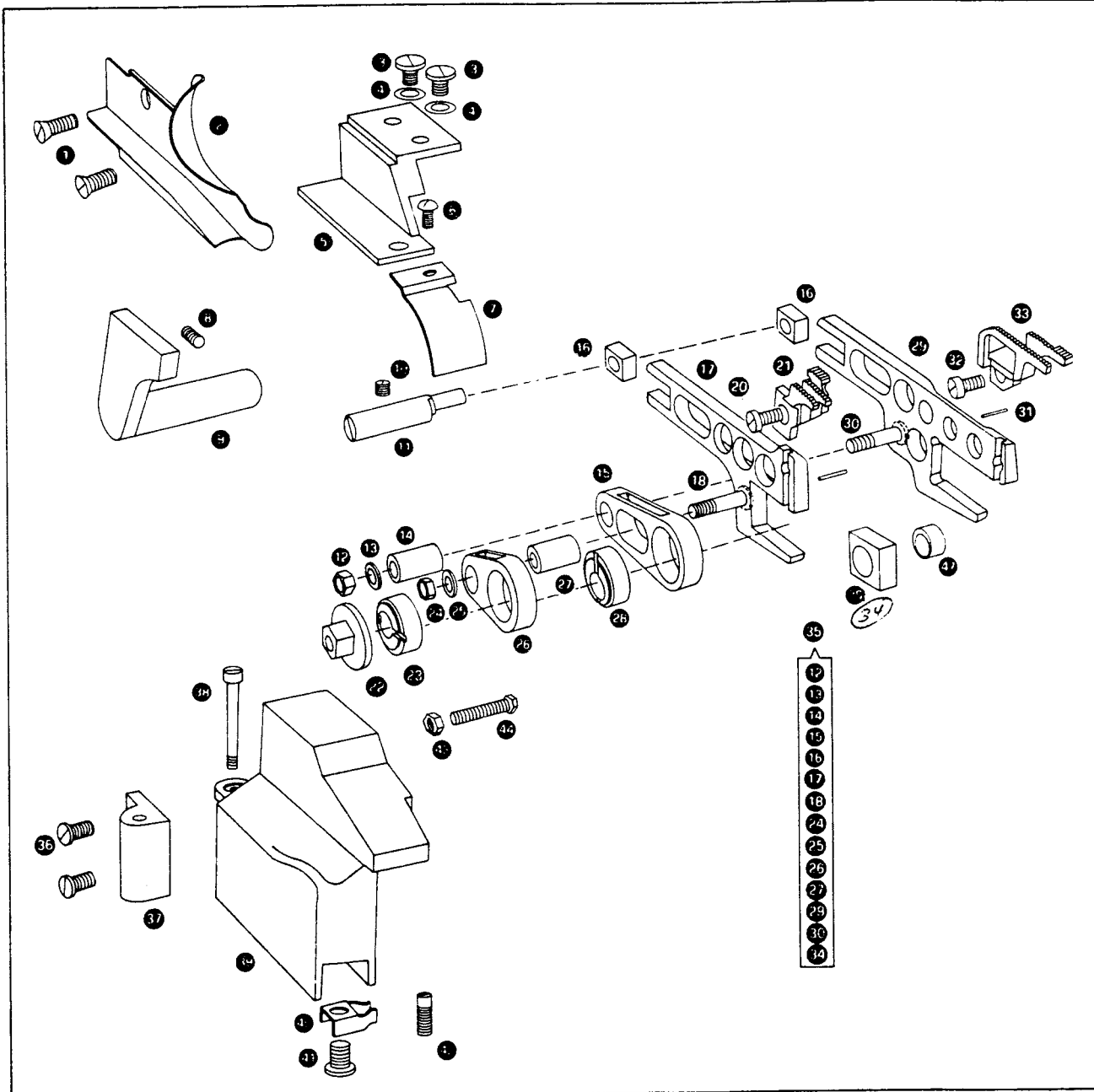
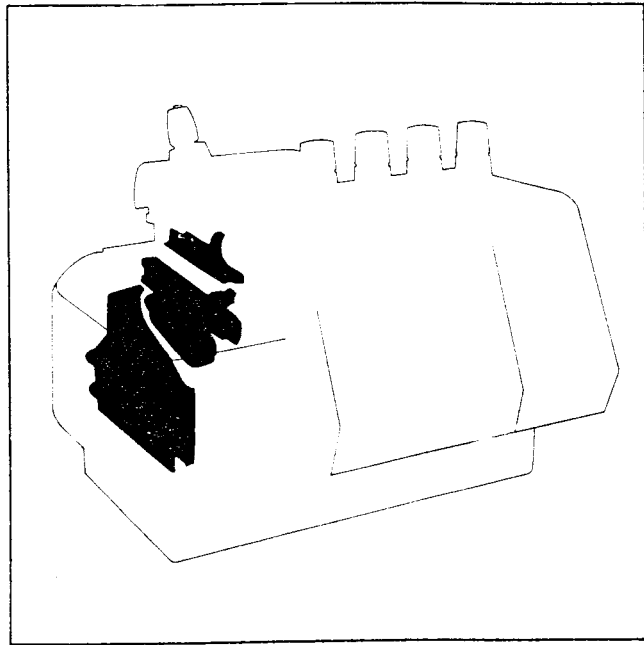

Parts List for 990B3 Machine

Ref. No.	Part No. For Ordering	Description	Amt Req.
1	107161	Presser Bar Bracket	
2	1143 (830)	Knife (moveable) Lever Hinge Stud Set Screw	
3	106466	Knife (moveable) Lever Hinge Stud.	
4	107575	Knife (moveable) Lever with two 141292 (869)	
5	141292 (869)	Knife (moveable) Lever Hinge Pin Set Screw	2
6	1259	Knife (moveable) Lever Bearing and Attachment Bracket Screw	
7	87029	Knife (moveable) Lever Bearing and Attachment Bracket	
8	87262	Knife (moveable) Lever Bearing and Attachment Bracket 87029 with 1259	
9	447 (830)	Knife (moveable) Lever Bearing and Attachment Bracket Set Screw (long)	
10	624 (830)	Knife (moveable) Lever Bearing and Attachment Bracket Set Screw (short)	
11	107192	Knife (moveable) Lifting Lever Retaining Washer and Oil Sling	
12	107628	Knife (moveable) Lifting Lever Needle Bearing	
13	107576	Knife (moveable) Lifting Lever	
14	1628 (809)	Knife (moveable) Lever Hinge Pin Bearing Lock Nut	
15	107188	Knife (moveable) Lever Hinge Pin	
16	107191	Knife (moveable) Lifting Lever Retaining Washer	
17	106455	Knife (moveable) Lever 107575 with 1628 (809), 106466, 107161, 107188 and 107576	
18	447 (830)	Knife (moveable) Lever Guide Set Screw	
19	106464	Knife (moveable) Lever Guide	
20	106454	Knife (moveable) Holder Adjusting Stud Block	} 103128
21	114072	Knife (moveable) Holder Screw Stud	
22	106132	Knife (moveable) Holder	
23	198 (819)	Knife (moveable) Holder Screw	
24	164550	Knife (moveable)	
25	165487	Knife (moveable) Guard (upper)	
26	106452	Knife (moveable) Guard (lower)	
27	1628 (819)	Knife (moveable) Holder Screw Stud Nut	
28	50611 (803)	Knife (stationary) and Needle Guard Holder Position Screw	2
29	164745	Knife (stationary) and Needle Guard Holder Body with two 50611 (803)	
30	141444 (831)	Knife (stationary) and Needle Guard Holder Screw	
31	164043	Knife (stationary) and Needle Guard Holder Spring	
32	164325	Knife (stationary) and Needle Guard Holder Spring Stud	
33	165062	Knife (stationary) and Needle Guard Holder	
34	164728	Knife (stationary)	
35	164744	Knife (stationary) Clamping Gib	
36	3146	Knife (stationary) Clamping Gib Screw Washer	
37	114032 (803)	Knife (stationary) Clamping Gib Screw	
38	165063	Knife (stationary) and Needle Guard Holder (adjustable) complete, Nos. 141444 (831), 164745 and 165062	
39	165064	Knife (stationary) and Needle Guard Holder with Gib complete, Nos. 3146, 114032 (803), 164744 and 165063	
40	141004 (830)	Knife (stationary) and Needle Guard Holder Locking Screw	
41	106472	Knife (stationary) and Needle Guard Holder Sleeve	
42	114130	Knife (stationary) and Needle Guard Holder Stud Set Screw	
43	106471	Knife (stationary) and Needle Guard Holder Stud	
44	113176	Knife (stationary) and Needle Guard Holder Stud Lock Nut	

Parts List for 990B3 Machine

Ref. No.	Part No. For Ordering	Description	Amt Req.
1	107161	Presser Bar Bracket	
2	1143 (830)	Knife (moveable) Lever Hinge Stud Set Screw	
3	106466	Knife (moveable) Lever Hinge Stud.	
4	107575	Knife (moveable) Lever with two 141292 (869)	
5	141292 (869)	Knife (moveable) Lever Hinge Pin Set Screw	2
6	1259	Knife (moveable) Lever Bearing and Attachment Bracket Screw	
7	87029	Knife (moveable) Lever Bearing and Attachment Bracket	
8	87262	Knife (moveable) Lever Bearing and Attachment Bracket 87029 with 1259	
9	447 (830)	Knife (moveable) Lever Bearing and Attachment Bracket Set Screw (long)	
10	624 (830)	Knife (moveable) Lever Bearing and Attachment Bracket Set Screw (short)	
11	107192	Knife (moveable) Lifting Lever Retaining Washer and Oil Sling	
12	107628	Knife (moveable) Lifting Lever Needle Bearing	
13	107576	Knife (moveable) Lifting Lever	
14	1628 (809)	Knife (moveable) Lever Hinge Pin Bearing Lock Nut	
15	107188	Knife (moveable) Lever Hinge Pin	
16	107191	Knife (moveable) Lifting Lever Retaining Washer	
17	106455	Knife (moveable) Lever 107575 with 1628 (809), 106466, 107161, 107188 and 107576	
18	447 (830)	Knife (moveable) Lever Guide Set Screw	
19	106464	Knife (moveable) Lever Guide	
20	106454	Knife (moveable) Holder Adjusting Stud Block	
21	114072	Knife (moveable) Holder Screw Stud	
22	106132	Knife (moveable) Holder	
23	198 (819)	Knife (moveable) Holder Screw	
24	164550	Knife (moveable)	
25	165487	Knife (moveable) Guard (upper)	
26	106452	Knife (moveable) Guard (lower)	
27	1628 (819)	Knife (moveable) Holder Screw Stud Nut	
28	50611 (803)	Knife (stationary) and Needle Guard Holder Position Screw	2
29	164745	Knife (stationary) and Needle Guard Holder Body with two 50611 (803)	
30	141444 (831)	Knife (stationary) and Needle Guard Holder Screw	
31	164043	Knife (stationary) and Needle Guard Holder Spring	
32	164525	Knife (stationary) and Needle Guard Holder Spring Stud	
33	165062	Knife (stationary) and Needle Guard Holder	
34	164728	Knife (stationary)	
35	164744	Knife (stationary) Clamping Gib	
36	3146	Knife (stationary) Clamping Gib Screw Washer	
37	114032 (803)	Knife (stationary) Clamping Gib Screw	
38	165063	Knife (stationary) and Needle Guard Holder (adjustable) complete, Nos. 141444 (831), 164745 and 165062	
39	165064	Knife (stationary) and Needle Guard Holder with Gib complete, Nos. 3146, 114032 (803), 164744 and 165063	
40	141004 (830)	Knife (stationary) and Needle Guard Holder Locking Screw	
41	106472	Knife (stationary) and Needle Guard Holder Sleeve	
42	114130	Knife (stationary) and Needle Guard Holder Set Screw	
43	106471	Knife (stationary) and Needle Guard Holder Stud	
44	113176	Knife (stationary) and Needle Guard Holder Stud Lock Nut	

check page 48

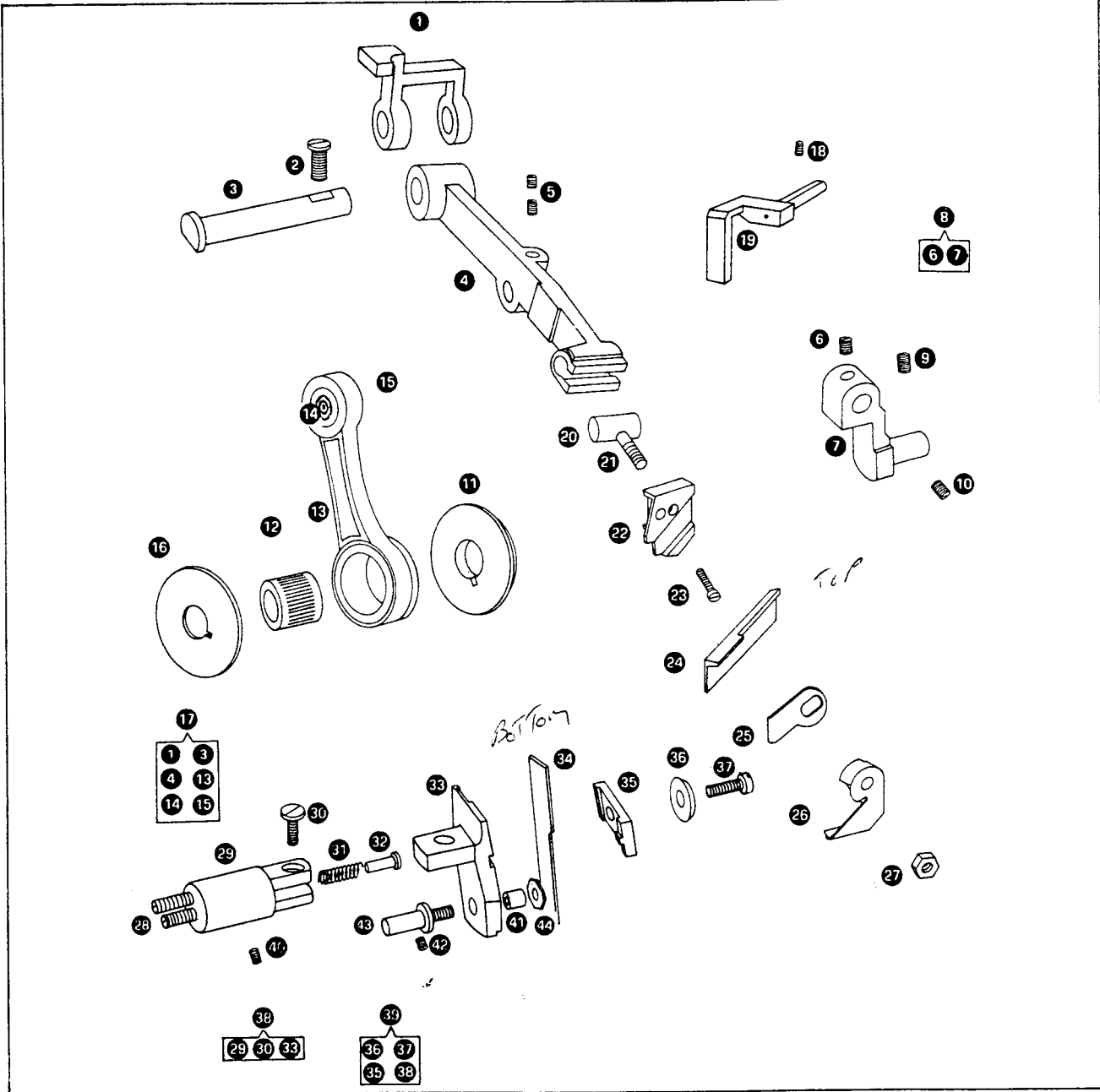
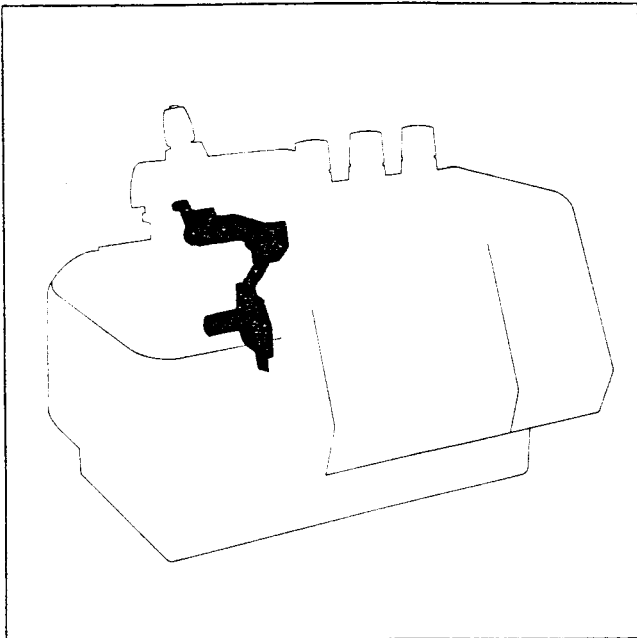

Parts List for 990B3 Machine

Ref. No.	Part No. For Ordering	Description	Amt. Req.
1	107045	Machine Pulley with 896 107036 and two 448 (830)	
2	448 (830)	Machine Pulley Set Screw	2
3	114077	Machine Frame Rotary Shaft Screw Stud	
4	107046	Machine Pulley Cap	
5	140416	Machine Pulley Cap Screw	
6	164100	Machine Frame Rotary Shaft Thrust Bearing	
7	139026	Machine Frame Rotary Shaft Ball Bearing	
8	164098	Machine Frame Rotary Shaft Oil Return and Ball Bearing Grease Retainer	
9	107177	Machine Frame Rotary Shaft Ball Bearing Retaining Ring	
10	107034	Machine Frame Rotary Shaft Ball Bearing Housing Gasket	
11	107033	Machine Frame Rotary Shaft Ball Bearing Housing	
12	51369 (803)	Machine Frame Rotary Shaft Ball Bearing Housing Screw	4
13	107035	Machine Frame Rotary Shaft Bushing (front)	
14	1036 (830)	Machine Frame Rotary Shaft Bushing (front) Set Screw	
15	448 (830)	Oil Pump Body Set Screw	
16	107061	Oil Pump Body with 448 (830)	
17	350647	Oil Pump Body Clamping Screw	
18	107065	Oil Pump Drive Pin	
19	107066	Oil Pump Rotor (inner)	
20	107067	Oil Pump Rotor (outer)	
		Note: Nos. 107066 and 107067 must be ordered as a set.	
21	107064	Oil Pump Cover	
22	1083 (805)	Oil Pump Cover Screw	3
23	108066	Oil Pump complete Nos., 1083 (805), 107061, 107064 107065, 107066 and 107067	

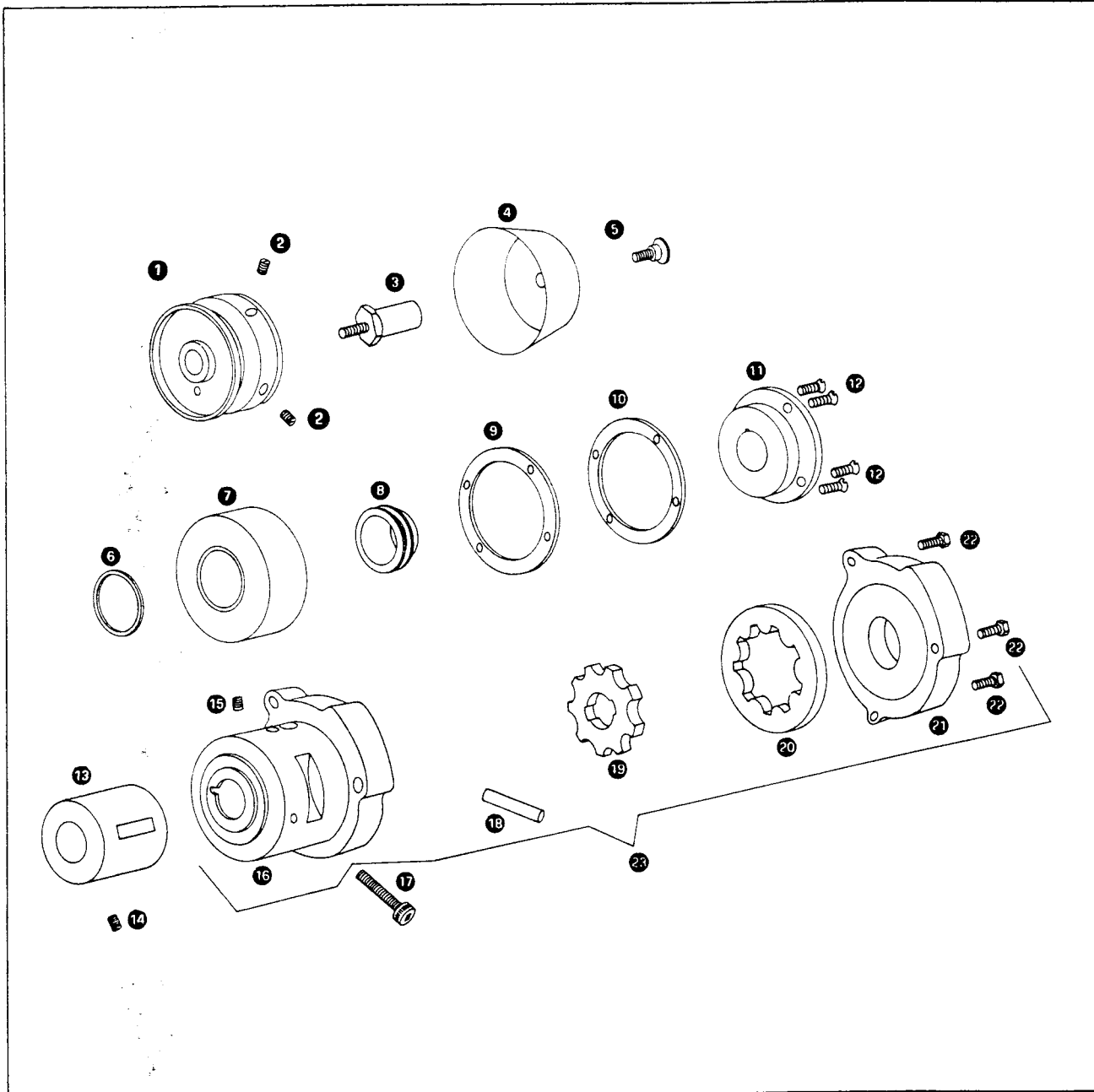
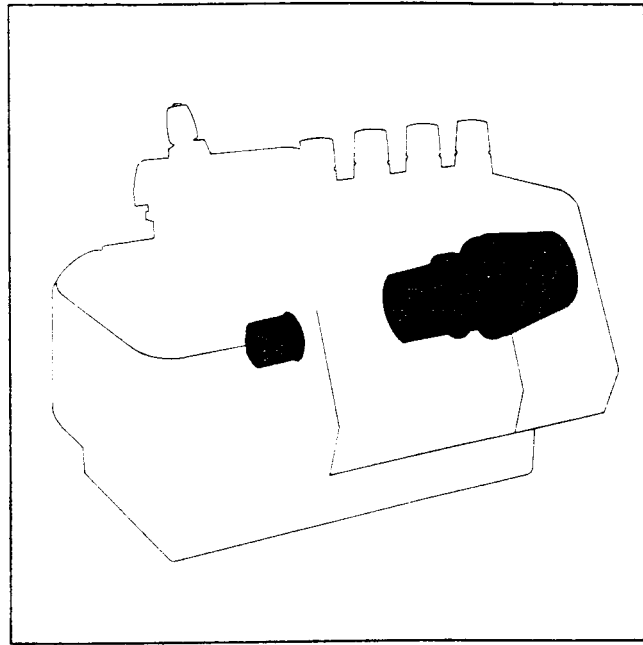

Parts List for 990B3 Machine

Ref. No.	Part No. For Ordering	Description	Amt. Req.
1	114083	Pressure Regulating Thumb Screw	
2	164416	Presser Bar (Upright) Spring (Heavy)	
		Note: Presser Bar (upright) Spring No. 164144 can be supplied as an alternative to No. 164416.	
3	107080	Presser Bar Lifting Lever	
4	50073 (809)	Knife (moveable) Lever and Presser Bar (upright) Housing Screw	2
5	106456	Knife (moveable) Lever and Presser Bar (upright) Housing with 460	
6	114082	Presser Bar (swing-out) Opening Lever Hinge Screw	
7	42436	Presser Bar (swing-out) Opening Lever Hinge Screw Washer	
8	107081	Presser Bar (swing-out) Opening Lever	
9	164143	Presser Bar (upright)	
10	51362 (830)	Presser Bar (swing-out) Pivot Screw Locking Plate Screw	
11	140510 (819)	Presser Bar (swing-out) Pivot Screw	
12	164351	Presser Bar (swing-out) Pivot Screw Locking Plate	
13	164139	Presser Bar Lifting Lever Spring	
14	1700 (819)	Presser Bar (swing-out) Lifting Screw Stud Nut	
15	82330	Presser Bar (swing-out)	
16	164141	Presser Bar (swing-out) Lifting Screw Stud	
17	462 (830)	Presser Bar Lifting Bracket Set Screw (short)	
18	106144	Presser Bar Lifting Bracket with 462 (830), 624 (830) and 51846	
19	51846	Presser Bar Lifting Bracket Roller and Stud	
20	624 (830)	Presser Bar Lifting Bracket Set Screw (long)	
21	107083	Presser Foot complete, Nos. 50169 (809), 50225 (809) 107082, 164146, 164147 and 164149	
	107082	Presser Foot Body	
	164146	Presser Foot Chaining-off Finger	
	164147	Presser Foot Clamping Plate	
	50225 (809)	Presser Foot Clamping Plate Screw	
	164149	Presser Foot Guide	
	50169 (809)	Presser Foot Guide Screw	
22	1094 (806)	Throat Plate Screw	2
23	107103	Throat Plate	
24	165055	Looper (left hand) Thread Tube (lower)	
25	853 (830)	Looper (left hand) Thread Tube (lower) Set Screw	
26	81433	Throat Plate Guide with 853 (830)	
27	1454 (805)	Throat Plate Guide Screw	
28	82281	Thread Eyelet (needle thread)	
29	460	Thread Eyelet (needle thread) Set Screw	
30	106457	Knife (moveable) lever and Presser Bar (upright) Housing complete Nos. 42436, 82281, 106144, 106456, 107080, 107081, 114082, 114083, 164139, 164143 and 164416	
31	114159	Pressure Regulating Thumb Screw Lock Screw	

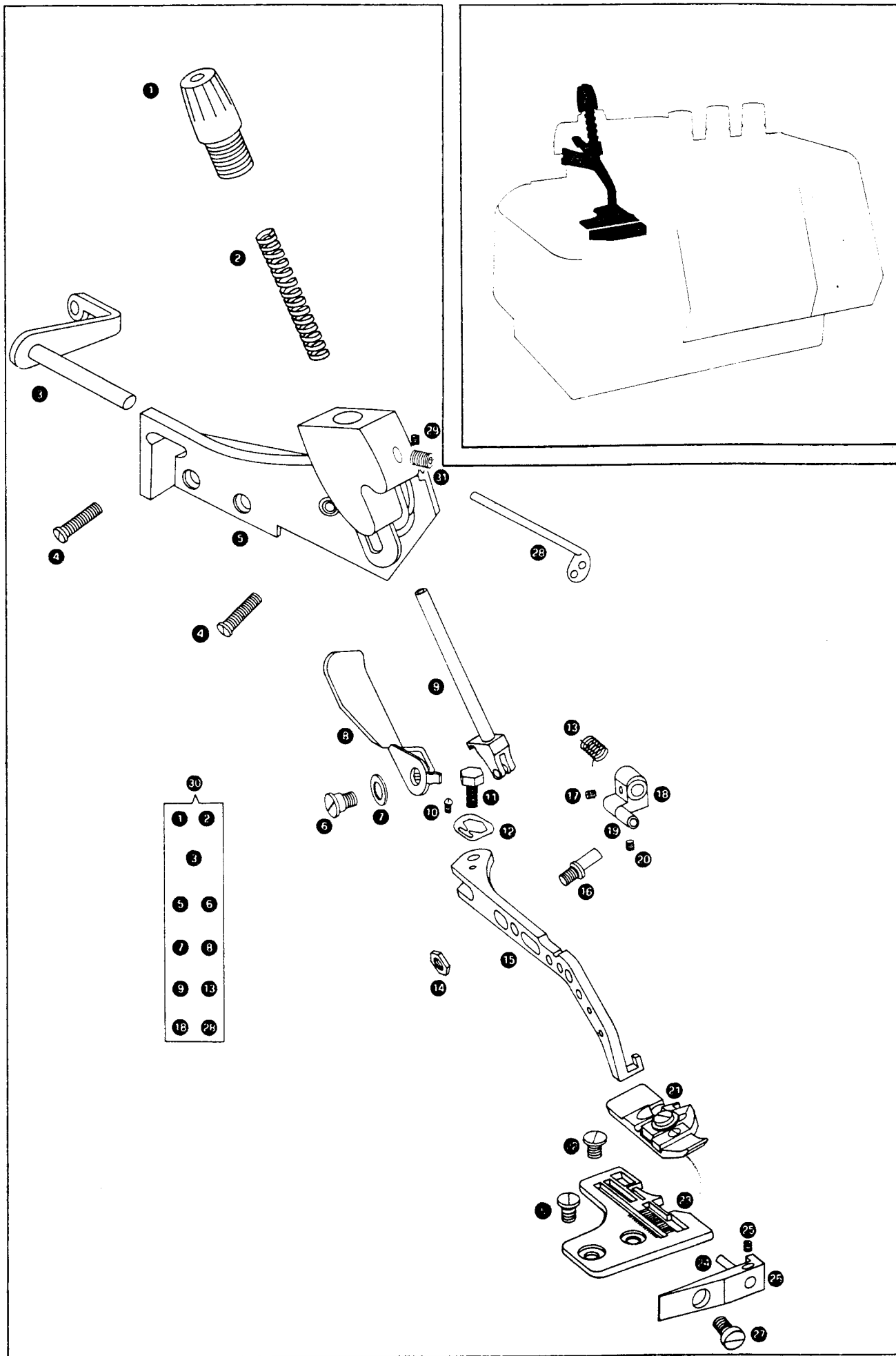

Parts List for 900B3 Machine

Ref. No.	Part No. For Ordering	Description	Amt. Req.
1	113180	Tension (light and heavy) Regulating Thumb Nut	3
2	107178	Tension (light and heavy) Spring Bushing	3
3	107084	Tension (heavy) Spring	2
4	164157	Tension (light) Spring	
5	107625	Tension (light and heavy) Spring Cover	3
6	2102	Tension (light and heavy) Disc	6
7	114117 (803)	Tension (light and heavy) Screw Stud	3
8	107087	Tension Thread Guide	3
9	1700 (888)	Tension (light and heavy) Lock Nut	3
10	107085	Tension (heavy) complete Nos. 107084, 107178, 107625, 113180, 113191, 114117 (803), and two 2102	2
11	107086	Tension (light) complete, Nos. 107178, 107625, 113180, 113191, 114117 (803), 164157 and two 2102	
12	114079 (819)	Oil Deflector Screw	
13	107102	Thread Guide Post	
14	107088	Thread Eyelet (needle thread) Bridge	
15	1423 (809)	Thread Eyelet (needle thread) Bridge Screw	
16	164462	Lint Stripper with 109935 (830)	
17	109935 (830)	Lint Stripper Set Screw	
18	114205 350677 (869)	Needle Clamp Screw	
19	108076	Needle Clamp	
20	108153	Needle Carrier with 108076, 108149, 108154, 350677 (869) and 350719 (869)	
21	350719 (869)	Needle Carrier Clamping Screw	
22	399 (830)	Thread (needle) Controller Screw	2
23	107620	Thread (needle) Controller	
24	108158	Oil Deflector	
25	107050	Needle Driving Shaft Bushing Lint Guard	
26	1238 (830)	Needle Driving Shaft Bushing Lint Guard Screw	
27	107049	Needle Driving Shaft Bushing	
28	109876	Needle Driving Shaft Bushing Locating Screw	
29	164053	Needle Driving Shaft Bushing Thrust Washer	
30	108069	Needle Driving Shaft	
31	Cat. 8100	Needle, size 11	
32	50225 (809)	Needle Guard Screw	
33	165058	Needle Guard	
34	165059	Needle Guard Holder	
35	1083 (805)	Needle Guard Holder Screw	
36	107025	Machine Frame Closing Plate	
37	1238 (806)	Machine Frame Closing Plate Screw	3
38	165406	Machine Frame Wearing Plate	
39	691 (803)	Machine Frame Wearing Plate Screw	2
40	108149	Needle Stop Pin	
41	108154	Needle Clamp Spacer	
42	113191	Tension (light and heavy) Regulating Thumb Nut Lock Nut	3

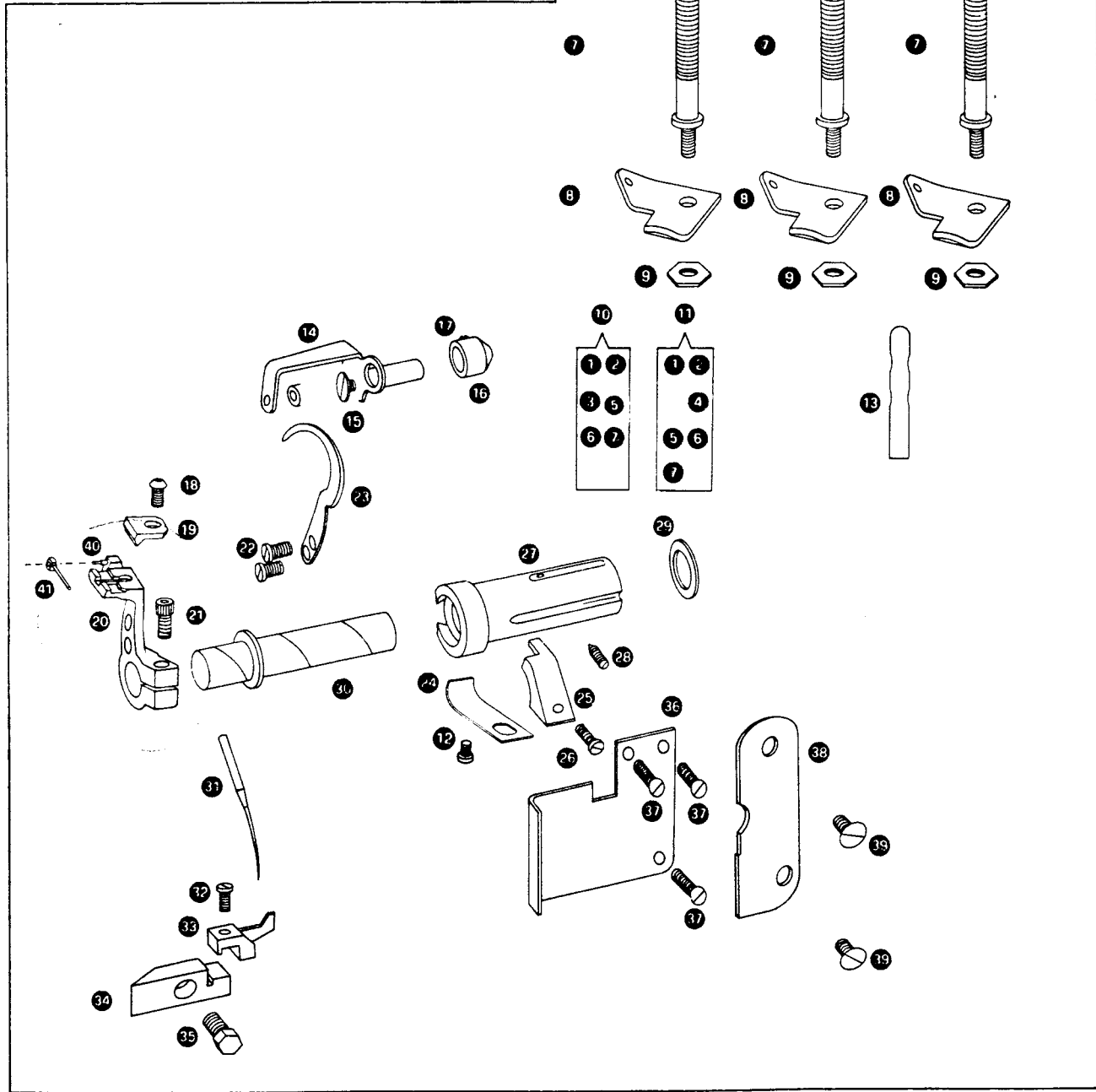
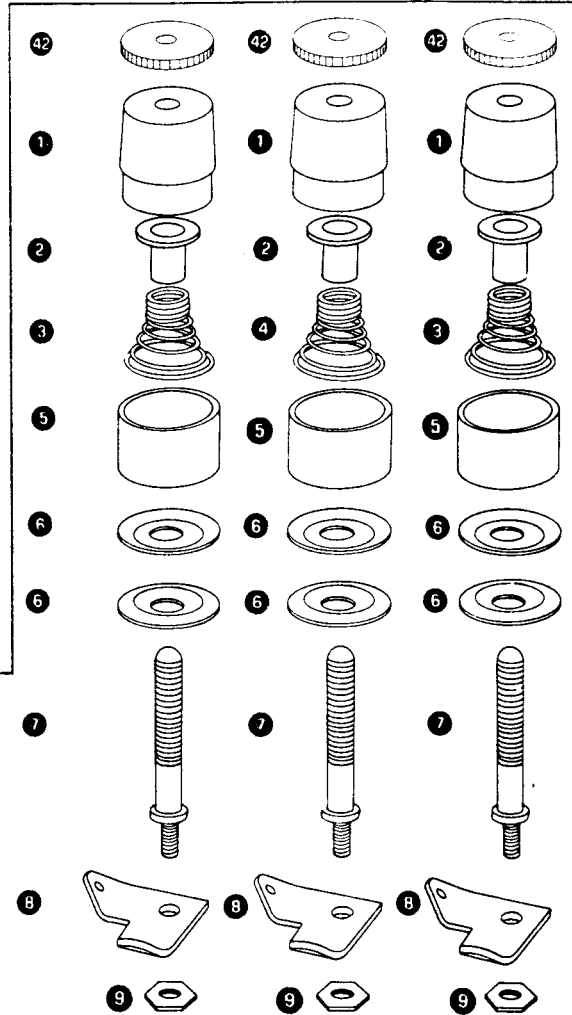
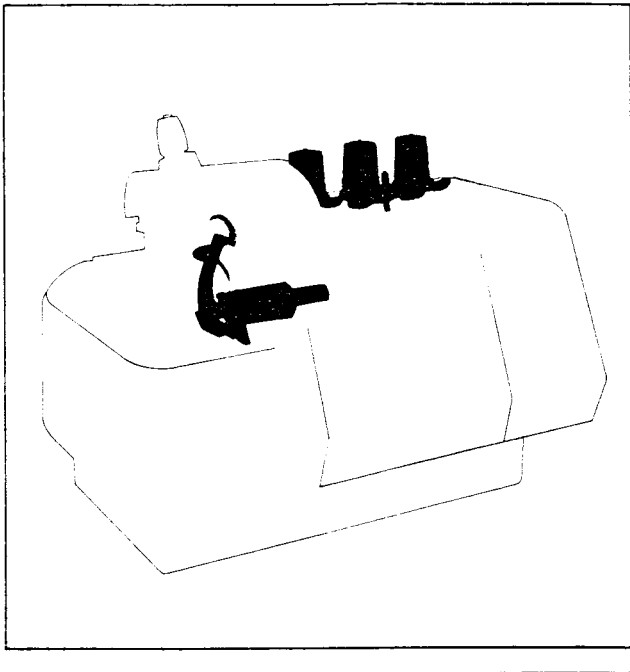

Parts List for 990B3 Machine

Ref. No.	Part No. For Ordering	Description	Amt. Req.
1	462 (830)	Thread (looper, right hand) Tube (lower) Set Screw	
2	101896	Thread (looper, right hand) Tube (lower)	
3	164176	Thread (looper) Take-up Plate	
4	164175	Thread (looper) Take-up	
5	164091	Thread (looper, right hand) Take-up	
6	190 (805)	Thread (looper) Take-up Screw (lower)	
7	1443 (809)	Thread (looper) Take-up Screw (lower)	
8	164163	Thread (looper, right hand) Take-up Eyelet (adjustable)	
9	1443 (809)	Thread (looper, right hand) Take-up Eyelet (adjustable) Screw	
10	17022	Thread (looper, right hand) Take-up Screw Washer	
11	187 (805)	Thread (looper, right hand) Take-up Screw	
12	164173	Thread (looper) Plate Thread Bushing	
13	50318 (818)	Thread (looper) Plate Thread Bushing Screw	
14	107091	Thread (looper) Plate with 462 (830)	
15	1239 (819)	Thread (looper) Plate Screw	2
16	164449	Thread (looper, right hand) Thread Eyelet (moveable)	
17	1423 (809)	Thread (looper, right hand) Thread Eyelet Screw	
18	1607 (809)	Thread (looper, right hand) Thread Eyelet (stationary) Nut	
19	164165	Thread (looper, right hand) Thread Eyelet (stationary)	
20	1094 (819)	Thread (looper) Plate Cover Latch Spring Screw	
21	107097	Thread (looper) Plate Cover Latch Spring	
22	107098	Thread (looper) Plate Cover Latch Spring Pin	
23	107093	Thread (looper) Plate Cover with 109927 (869)	
24	107095	Thread (looper) Plate Cover Hinge Bracket	
25	175032	Thread (looper) Plate Cover Hinge Bracket Screw Washer	2
26	1209 (819)	Thread (looper) Plate Cover Hinge Bracket Screw	2
27	107096	Thread (looper) Plate Cover Hinge Pin	
28	109927 (869)	Thread (looper) Plate Cover Hinge Pin Locking Screw	
29	107092	Thread (looper) Plate complete, Nos. 1423 (809), 1443 (809), 1607 (809), 50318 (818), 101896, 107091, 164163, 164165, 164173, and 164449	
30	107094	Thread (looper) Plate Cover 107093 with 1094 (819), 107095, 107096 and 107097	
Not Illustrated:-			
--	107040	Machine Frame Top Cover Assembly Nos. 107039, 107086, 107102, two each 107085, 107090 and three 107087	
--	106500	Machine Frame Bracket Assembly	
--	107024	Machine Frame Bracket Key	
--	187 (805)	Machine Frame Bracket Key Screw	
--	350744 (869)	Machine Frame Bracket Screw	

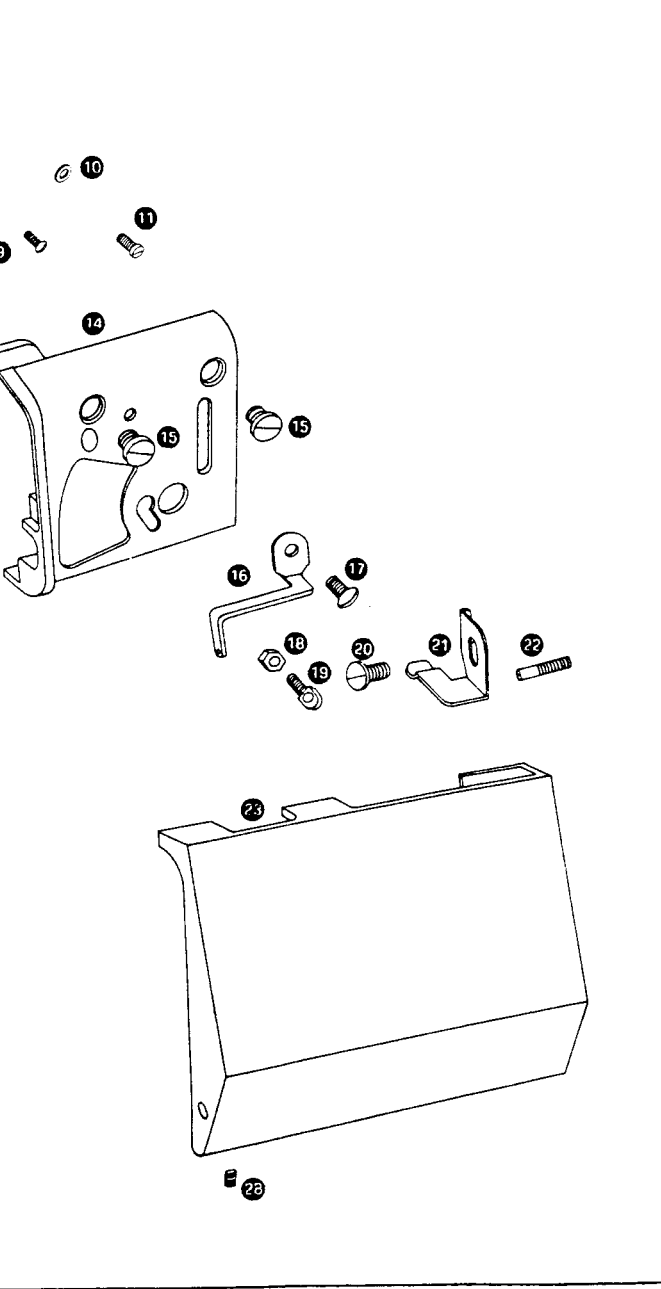
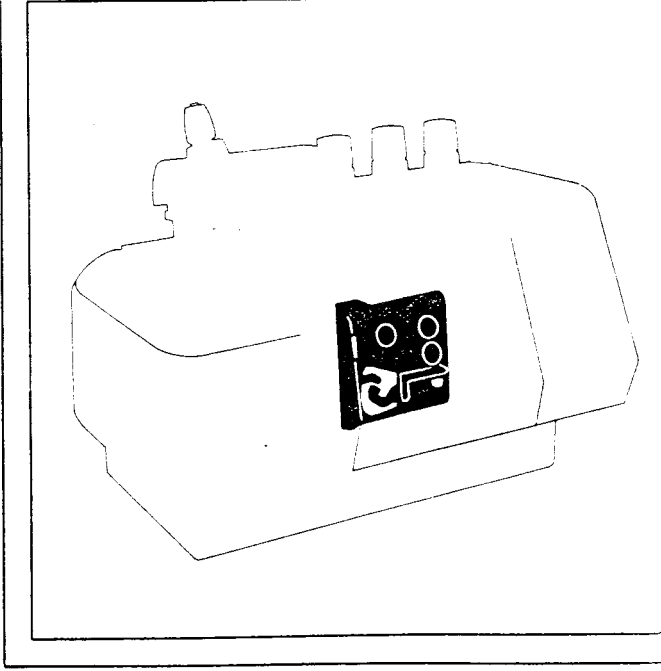
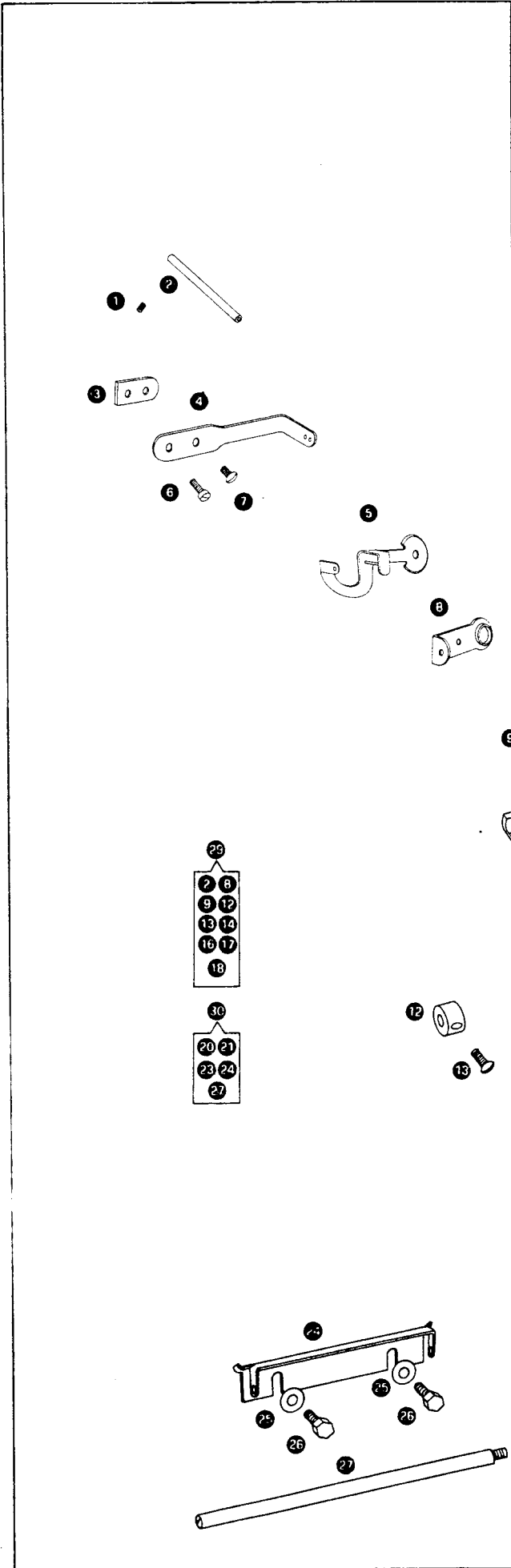

Parts List for 990B3 Machine

Ref. No.	Part No. For Ordering	Description	Amt. Req.
1	107587	Oil Cup	
2	225 (819)	Looper (right hand) carrier Connecting Link Adjusting Sleeve Wick Clip Screw	
3	20822	Looper (right hand)) Carrier Connecting Link Adjusting Sleeve Wick Clip	
4	165384	Machine Frame Oil Drain Plate Screen	
5	165519	Machine Frame Oil Drain Plate Filter (Felt)	
6	165395	Machine Frame Oil Drain Plate	
7	1454 (830)	Machine Frame Oil Drain Plate Screw	2
8	113179	Oil Pump Relief Valve Spring Screw Stud Locking Nut	
9	114081	Oil Pump Relief Valve Spring Screw Stud	
10	107078	Oil Pump Relief Valve Spring	
11	107077	Oil Pump Relief Valve Plunger	
12	107075	Oil Pump Relief Valve	
13	107076	Oil Pump Relief Valve Body	
14	107079	Oil Pump Relief Valve Complete Nos. 107075, 107076, 107077, 107078, 113179 and 114081	
15	114140	Oil Pump Suction Filter Hole Plug Screw	
16	108104	Oil Pump Suction Filter Spring	
17	108113	Oil Pump Suction Filter	
18	107074	Oil Pump Suction Filter Hole Plug Screw Gasket	
19	108063	Oil Pump Suction Filter Complete Nos 107074, 108113, 108104, 1480, and 114114	
20	107070	Oil Reservoir Gasket	
21	107068	Oil Reservoir	
22	107204	Oil Reservoir Drain Plug	
23	106401	Oil Reservoir Oil Sight Gauge Seal	
24	107071	Oil Reservoir Oil Sight Gauge	
25	350744	Oil Reservoir Screw	6
26	107069	Oil Reservoir 107068 with 106401, 107071 and 107204	
27	107158	Machine Frame Oil Pressure Gauge Connection Plug Gasket	
28	107029	Machine Frame Oil Pressure Gauge Connection Plug	
29	147070	Oil Pump Body Clamping Screw Hole Plug Screw Washer	
30	114038 (869)	Oil Pump Body Clamping Screw Hole Plug Screw	
31	165157	Oil Return Filter (front) Fastener	
32	107898	Oil Return Filter (front) Screw SCREEN	
33	149224	Oil Return Filter (front) Pad	
34	107169	Oil Return Filter (front) Complete Nos. 107898, 149224 and 165157	
35	1480	Oil Pump Suction Filter Securing Screw	

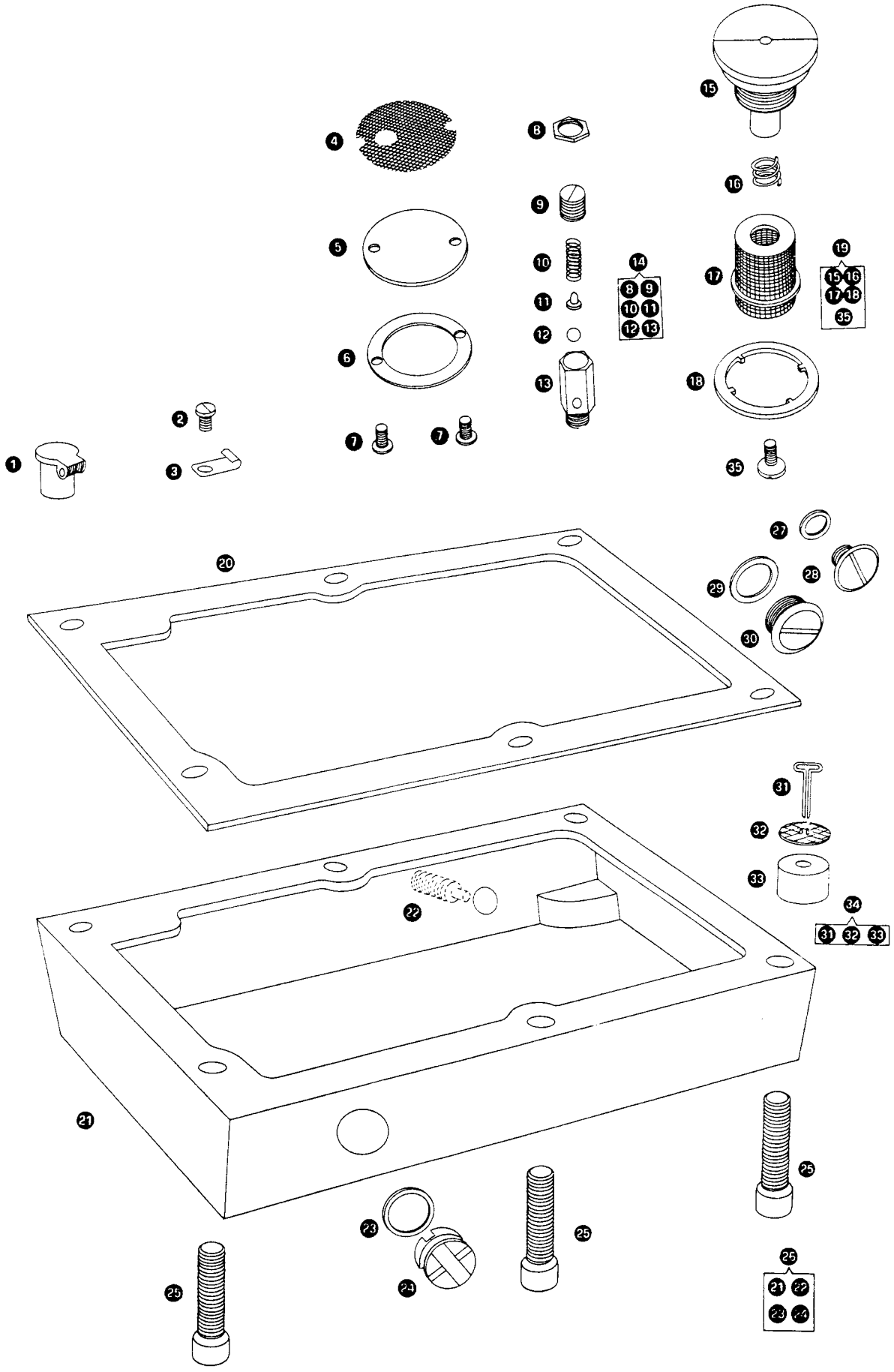

Parts List for 990B3 Machine

Ref. No.	Part No. For Ordering	Description	Amt. Req.
1	114131 (832)	Presser Bar Lifting Lever Stop Screw	
2	1637 (810)	Presser Bar Lifting Lever Stop Screw Nut	
3	106458	Knife (moveable) lever and Presser Bar (upright) Housing Cover with 109927 (869)	
4	114073	Knife (moveable) Lever and Presser Bar (upright) Housing Cover Hinge Bracket Screw	2
5	106460	Knife (moveable) Lever and Presser Bar (upright) Housing Cover Hinge Pin	
6	106459	Knife (moveable) Lever and Presser Bar (upright) Housing Cover Hinge Bracket	
7	109927 (869)	Knife (moveable) Lever and Presser Bar (upright) Housing Cover Hinge Pin Locking Screw	
8	114082 (819)	Knife (moveable) Lever and Presser Bar (upright) Housing Cover Stop Plate Screw	2
9	42436	Knife (moveable) Lever and Presser Bar (upright) Housing Cover Stop Plate Screw Washer (quantity as required)	
10	106463	Knife (moveable) Lever and Presser Bar (upright) Housing Cover Stop Plate	
11	106461	Knife (moveable) Lever and Presser Bar (upright) Housing Cover Latch Spring	
12	227 (819)	Knife (moveable) Lever and Presser Bar (upright) Housing Cover Latch Spring Screw	
13	106462	Knife (moveable) Lever and Presser Bar (upright) Housing Cover Latch Spring Pin	
14	113176 (819)	Knife (moveable) Lever and Presser Bar (upright) Housing Cover Latch Spring Pin Lock Nut	
15	50073 (809)	Machine Frame Top Cover Screw	2
16	107039	Machine Frame Top Cover with two 107090	
17	107090	Looper (left hand) Thread Tube (upper)	
18	107090	Looper (right hand) Thread Tube (upper)	
19	691 (819)	Machine Frame Top Cover Closing Plate Screw	6
20	107042	Machine Frame Top Cover Closing Plate with 107059	
21	107059	Oil Flow Indicator	
22	107060	Oil Flow Indicator Nozzle	
23	107044	Machine Frame Top Cover Closing Plate Gasket	
24	106439	Cloth Plate	
25	106437	Cloth Plate Hinge Bracket Hinge Pin	
26	106436	Cloth Plate Hinge Bracket	
27	51369	Cloth Plate Hinge Bracket Screw	2
28	106435	Cloth Plate Extension	
29	1700 (819)	Cloth Plate Position Screw Nut	
30	114112 (830)	Cloth Plate Position Screw	
31	931084 (819)	Cloth Plate Extension Bracket Screw Lock Washer	
32	114112 (830)	Cloth Plate Extension Bracket Screw	
33	109927 (869)	Cloth Plate Hinge Bracket Hinge Pin Locking Screw	
34	51408 (830)	Cloth Plate Lock Spring Screw	
35	931084 (819)	Cloth Plate Lock Spring Screw Washer	
36	164205	Cloth Plate Lock Spring	
37	107180	Cloth Plate Extension Closing Plate	
38	934 (810)	Cloth Plate Extension Closing Plate Screw	2
39	107198	Cloth Plate Extension 106435 with 107180 and two 934 (810)	
40	106440	Cloth Plate with Extension complete Nos. 1700 (819), 51408 (830), 106439, 107198, 164205, two each 114112 (830) and 931084 (819)	
41	1250	Cloth Plate Lock Spring Retaining Screw Stud	
42	140509 (809)	Chip Guard Screw (upper)	
43	106433	Chip Guard	
44	1209 (809)	Chip Guard Screw (lower)	
45	114142 (809)	Belt Cover Screw	2
46	106430	Belt Cover	

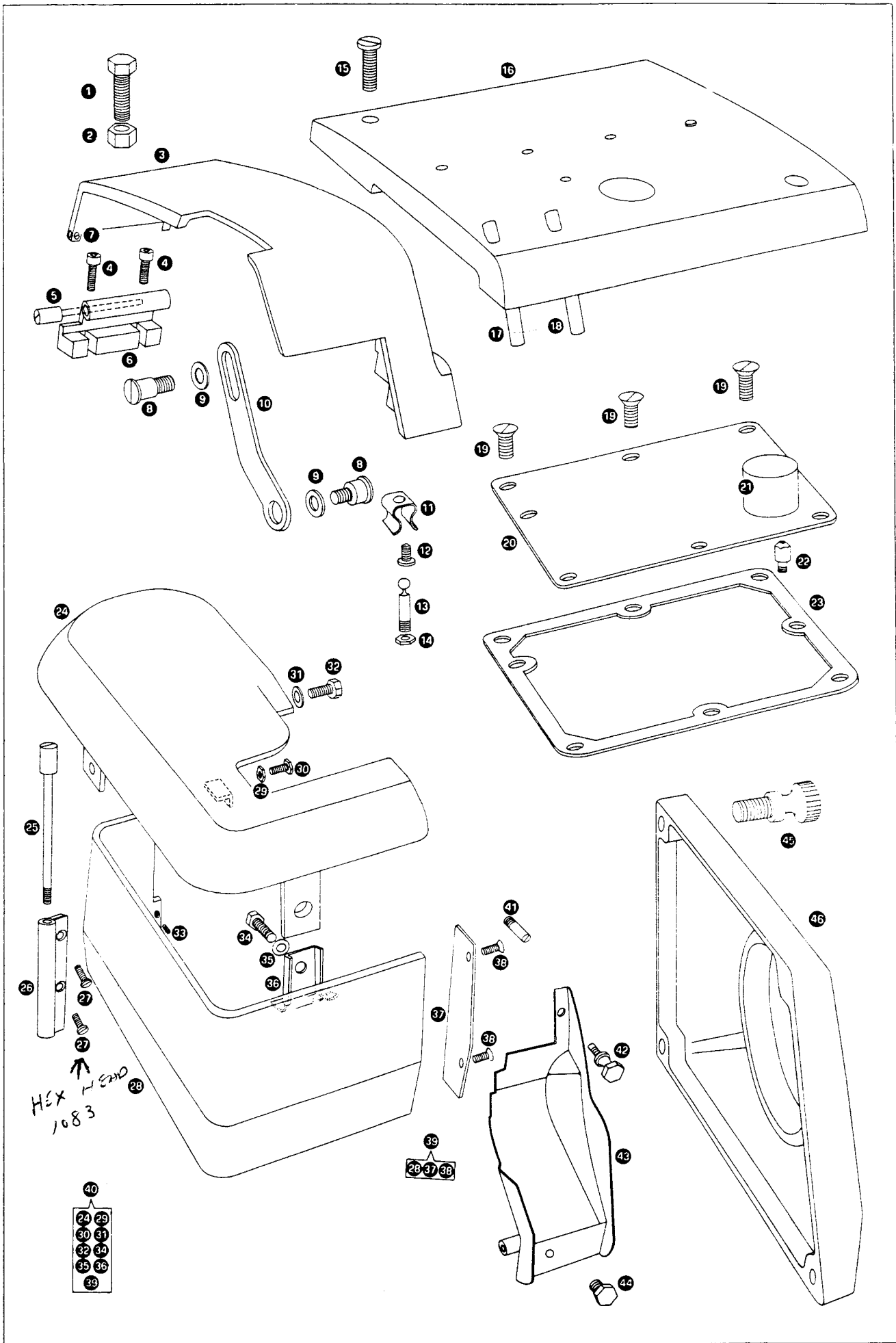

Parts List for 990B3 Machine—Accessories

Ref. No.	Part No. For Ordering	Description	Amt. Req.
Supplied with Machine			
1	161294	Screw Driver	
2	108146	Wrench (plastic handle)	
3	108148	Accessory Box (plastic)	
4	108123	Belt Cover (rear)	
5	—	Belt Cover (rear) Wood Screw 3/8 inch (10mm) No. 6 R.H.	2
6	164164	Thread (looper, right hand) Thread Eyelet (moveable)	
7	820193-002	Wrench for 1/16 inch (1.6mm) socket head screw	
	820193-005	Wrench for 1/8 inch (3.2mm) socket head screw	
	820193-006	Wrench for 5/32 inch (4mm) socket head screw	
	820193-007	Wrench for 3/16 inch (4.8mm) socket head screw	
	820193-009	Wrench for 3/32 inch (2.4mm) socket head screw	
	820193-010	Wrench for 7/32 inch (5.6mm) socket head screw	
8	68547	Wrench (flat)	
9	10875	Wrench (flat)	
10	164203	Feed Eccentric Extractor	
11	164196	Threader	6
12	164550	Knife (moveable)	
13	Cat. 8100	Needles, size 11 (or according to fittings being supplied)	6
14	108057	Tweezers	
15	164728	Knife (stationary)	
16	81350-011	Tin of Oil (1 pint, 0.57 litres, type 'H' Oil)	
17	108065	Oil Dispenser	
18	108147	Oil Funnel	
19	107627	Lint Brush	
20	81443	Thread Unwinder (3 spools)	
	or		
	81444	Thread Unwinder (4 spools)	6
21	108154	Needle Clamp Spacer	6
22	164727	Knee Lifter (supplied in place of Foot Lifter if requested)	
Available at an Extra Charge			
23	82253	Gauge	
—	108058	Dust Cover (not illustrated)	
24	107936	Oil Pressure Gauge	
25	108224	Earthing Wire	
26	49109	Earthing Wire Washer	
27	701679	Earthing Wire Lock Washer	
28	176(809)	Earthing Wire Screw	

SUPPLIED WITH MACHINE

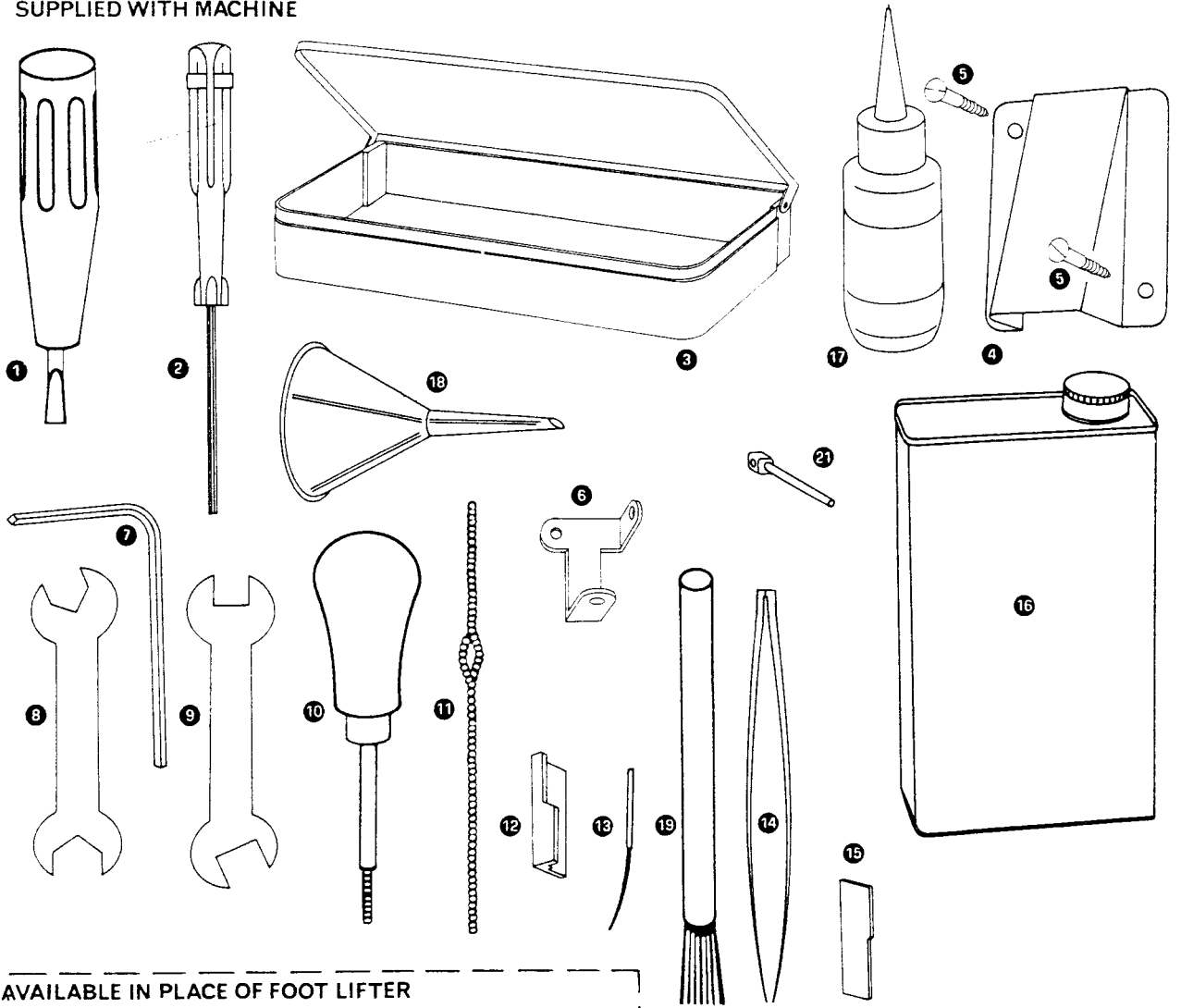

AVAILABLE IN PLACE OF FOOT LIFTER

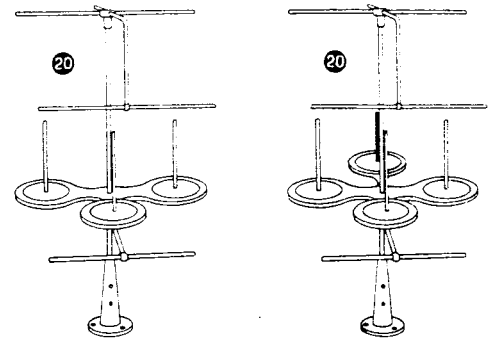
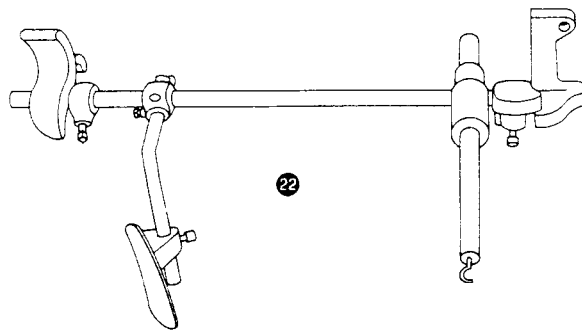

AVAILABLE AT EXTRA CHARGE

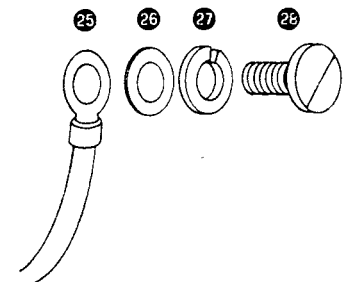
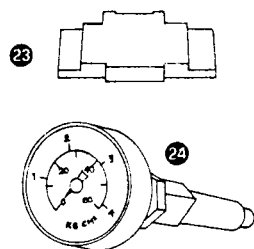

Parts List for 990B3 Machine—Accessories

Ref. No.	Part No. For Ordering	Description	Amt. Req.
Available at an Extra Charge			
1	1700(809)	Chip Chute Support Bracket Screw Nut	4
2	175032	Chip Chute Support Bracket Screw Washer	4
3	107156	Chip Chute Support Bracket (left hand)	
4	1094(809)	Chip Chute Support Bracket Screw	4
5	107157	Chip Chute Support Bracket (right hand)	
6	107105	Chip Chute (long)	
	or		
	108217	Chip Chute (short)	
7	107514	Chip Chute Sleeve	
8	107989	Chip Chute (long) complete. Nos. 107105, 107156, 107157, 107514, four each 1094(809), 1700(809) and 175032	
9	108219	Chip Chute (short) complete. Nos. 107156, 107157, 107514, 108217, four each 1094(809), 1700(809) and 175032	
Supplied with Machine			
10	51797	Machine Base Mounting Screw Insert	4
11	9842	Machine Base Mounting Screw Washer	4
12	350647(869)	Machine Base Mounting Screw	4
13	81231	Machine Cushion (large)	2
14	164189	Machine Cushion (small)	2
15	108220	Machine Base Support Tube End Plug	2
16	20437	Chip Chute Support Bracket (left hand) Screw (upper) Washer	
17	114116	Chip Chute Support Bracket (left hand) Screw (upper)	
18	(107107)	Machine Base complete with 20437, 114116 two each 81231, 108220, 164189, four each 9842, 51797 and 350647(869)	
	115 765		

AVAILABLE AT AN EXTRA CHARGE

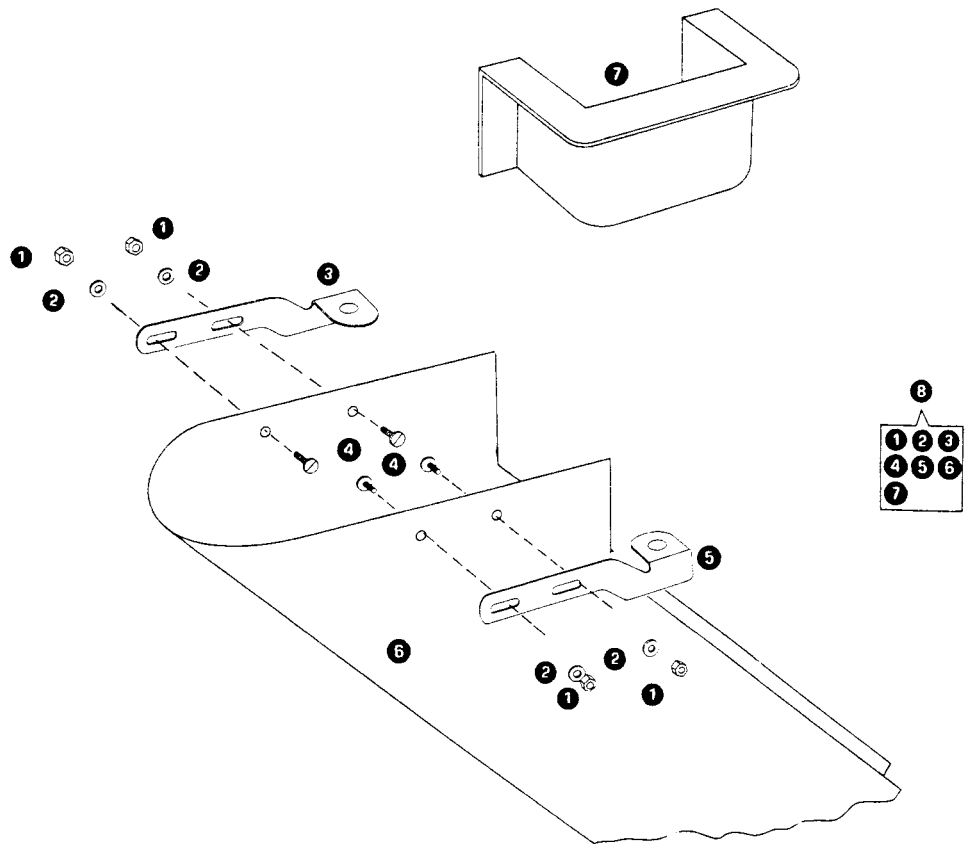

SUPPLIED WITH MACHINE

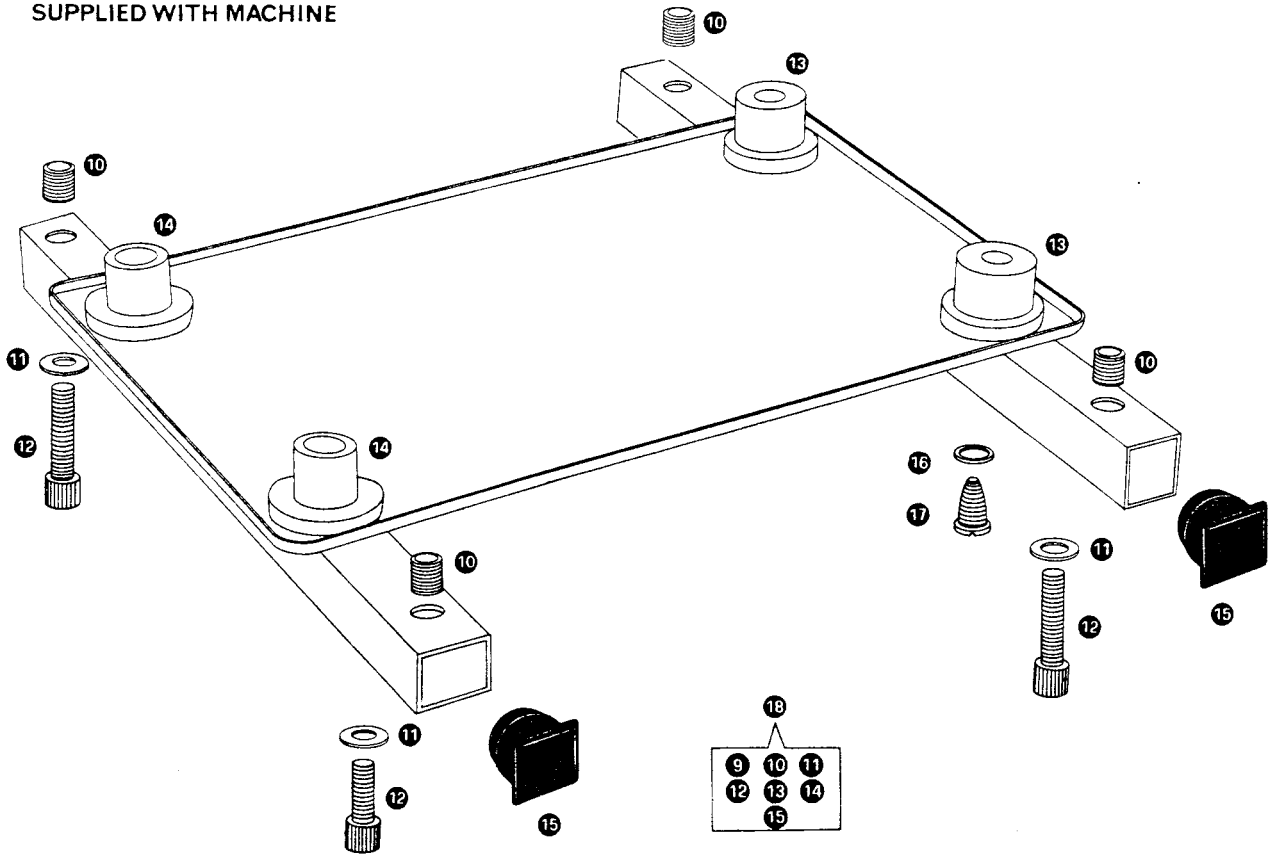

Parts List for 990B3 Machine – Accessories

Ref. No.	Part No. For Ordering	Description	Amt. Req.
Supplied with Machine			
1	107501	Foot Lifter Operating Cable	
2	140393	Foot Lifter Operating Cable Retaining Collar Screw	
3	107505	Foot Lifter Operating Cable Retaining Collar with 140393	
4	107513	Foot Lifter Operating Cable complete, Nos. 107501 and 107505	
5	164042	Foot Lifter Operating Cable Friction Sleeve	
Listed below are foot treadles suitable for floor mounting, mounting to the round cross brace of a stand, or mounting to the flat pressed steel treadle support of a stand. The customer is required to specify which treadle, if any, he requires and it will be supplied at no charge.			
Treadle for Floor Mounting			
6	152168	Treadle	
7	152169	Treadle 152168 with 51723, 152170, 152171 and 67425	
8	107626	Treadle 152169 with two 107502 and four wood screws 1" No. 16 F.H.	
9	152170	Treadle Extension	
10	152171	Treadle Extension Swivel Stud	
11	51723	Treadle Extension Wing Nut	
12	67425	Treadle Extension Wing Nut Lock Washer	
13	107502	Treadle Hinge Bracket	
14	—	Treadle Hinge Bracket Wood Screw 1" No. 16 F.H.	
Treadle for Mounting to Round Cross Brace			
6	152168	Treadle	
7	152169	Treadle 152168 with 51723, 152170, 152171 and 67425	
19	152095	Treadle 152169 with 152153 and two 152080	
9	152170	Treadle Extension	
10	152171	Treadle Extension Swivel Stud	
11	51723	Treadle Extension Wing Nut	
12	67425	Treadle Extension Wing Nut Lock Washer	
15	152080	Treadle Position Collar with 51089	
16	51089	Treadle Position Collar Bolt with 51581	
17	51581	Treadle Position Collar Bolt Nut	
18	152153	Treadle Spring	
Treadle for Mounting to Flat Pressed Steel Treadle Support			
6	152168	Treadle for 152169	
7	152169	Treadle 152168 with 51723, 152170, 152171 and 67425	
26	107546	Treadle 152169 with two 107512	
9	152170	Treadle Extension	
10	152171	Treadle Extension Swivel Stud	
11	51723	Treadle Extension Wing Nut	
12	67425	Treadle Extension Wing Nut Lock Washer	
13	107502	Treadle Hinge Bracket	
25	107512	Treadle Hinge Bracket 107502 with two each 23250, 51082-002 and 67425	
20	141223-002	Treadle Hinge Bracket Bolt	
21	51082-002	Treadle Hinge Bracket Bolt 141223-002 with 51581	
22	51581	Treadle Hinge Bracket Bolt Nut	
23	67425	Treadle Hinge Bracket Bolt Nut Lock Washer	
24	23250	Treadle Hinge Bracket Bolt Washer	
Available at an extra charge			
For use with table mounted motors and Series 52, 53 motors.			
25	108221	Presser Bar Lifter Connecting Cable	
26	108222	Presser Bar Lifter Operating Arm	
27	5599	Presser Bar Lifter Operating Arm Bracket	
28	5601	Presser Bar Lifter Operating Arm Hinge Pin	
29	—	Presser Bar Lifter Operating Arm Bracket Wood Screw 1 inch (25mm) No. 8 F.H.	2
30	108223	Presser Bar Lifter Operating Arm complete, Nos. 5599, 5601, 108221, 108222 and two 8905 and Wood Screws 1 inch (25mm) No. 8 F.H.	
Not Illustrated:- 8905 Presser Bar Lifter Operating Arm Bracket Washer			2

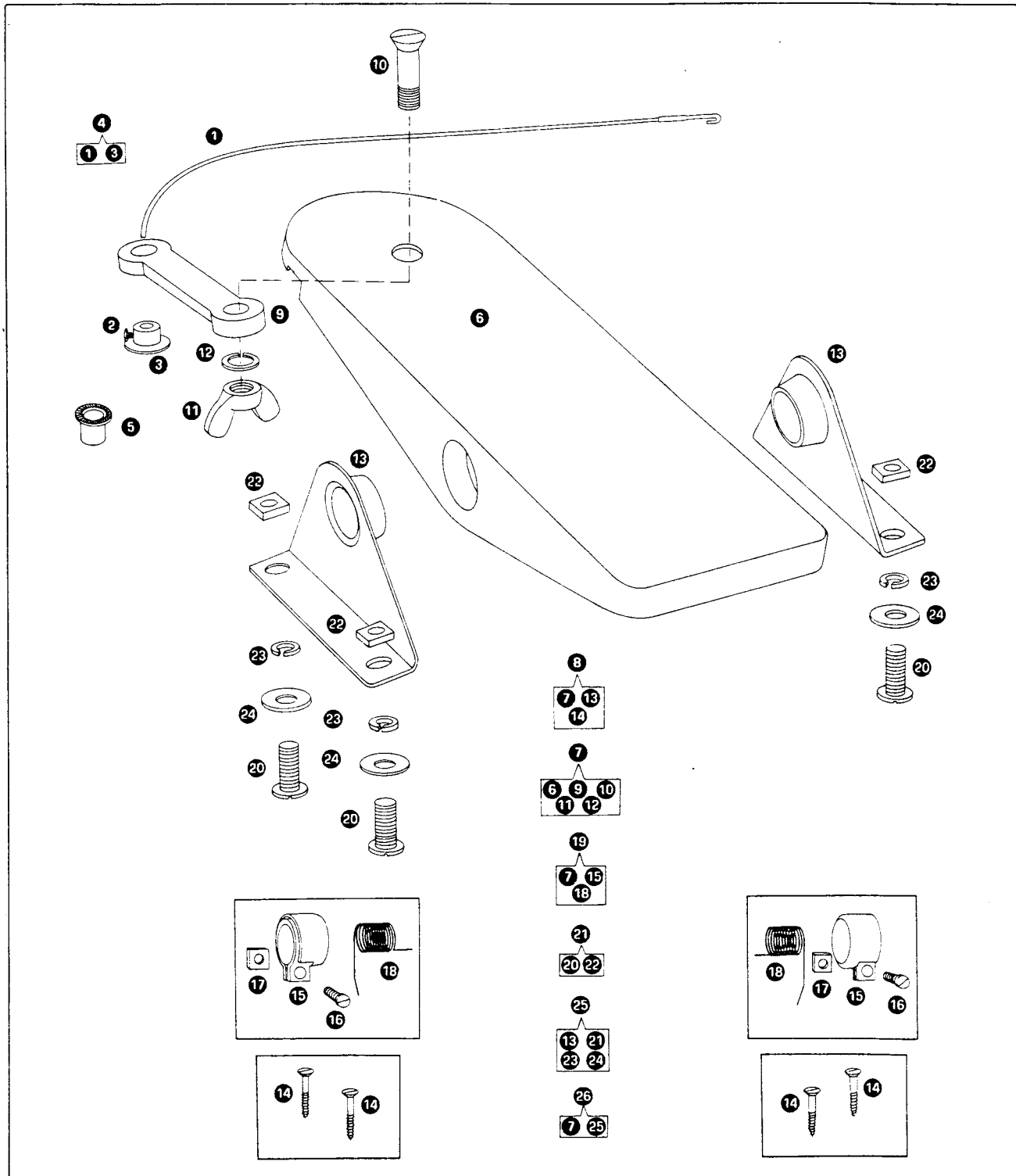

Available at an extra charge

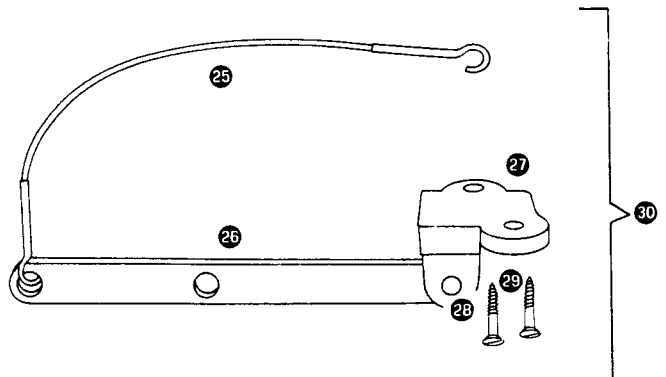

Parts List for 990B5 Machine

The following parts differ from those used on 990B3 Machine

All other parts are the same

Ref. No.	Part No. For Ordering	Description	Amt. Req.
1	107636	Thread (needle) Controller	
2	107635	Needle Driving Shaft Bushing	
3	Cat. 8100	Needle, size 14	
4	108399 (107976)	Knife (movable) Lifting Lever	
5	107797	Knife (movable)	
6	107633	Machine Frame Rotary Shaft	
		See Note under No. 107031 on page 46	
7	164380	Presser Foot complete, Nos. 50169(809), 50225(809), 164147, 1643601, 164378 and 164379	
	164378	Presser Foot Body	
	164379	Presser Foot Chaining-off Finger	
	164360	Presser Foot Guide	
8	81425-003	Throat Plate	
9	164369	Feed (back) Dog	
10	165106	Feed (front) Dog	
11	106445-010	Feed (back) Eccentric (10 stitches per inch)	
12	106445-010	Feed (front) Eccentric (10 stitches per inch)	
13	165134	Feed Bar Slide Block (front)	
14	101832	Feed Lifting Eccentric	
15	107631	Looper (left hand)	
16	87028	Looper (right hand)	
17	107637	Thread (looper) Plate Cover with 109927(869)	
Not illustrated			
—	107638	Thread (looper) Plate Cover 107637 with 1094(819), 107095, 107096 and 107097	
—	107629	Feed (back) and (front) Bars complete, Nos. 106442, 106447, 107160, 164006, 164018, 164687, 165134, two each 1718(803), 9525(803), 164004 and 164009	
Accessories			
Supplied with machine			
18	107797	Knife (movable)	
19	Cat. 8100	Needles, six, size 14 (or according to fittings being supplied)	
Available at an extra charge			
20	82254	Gauge	

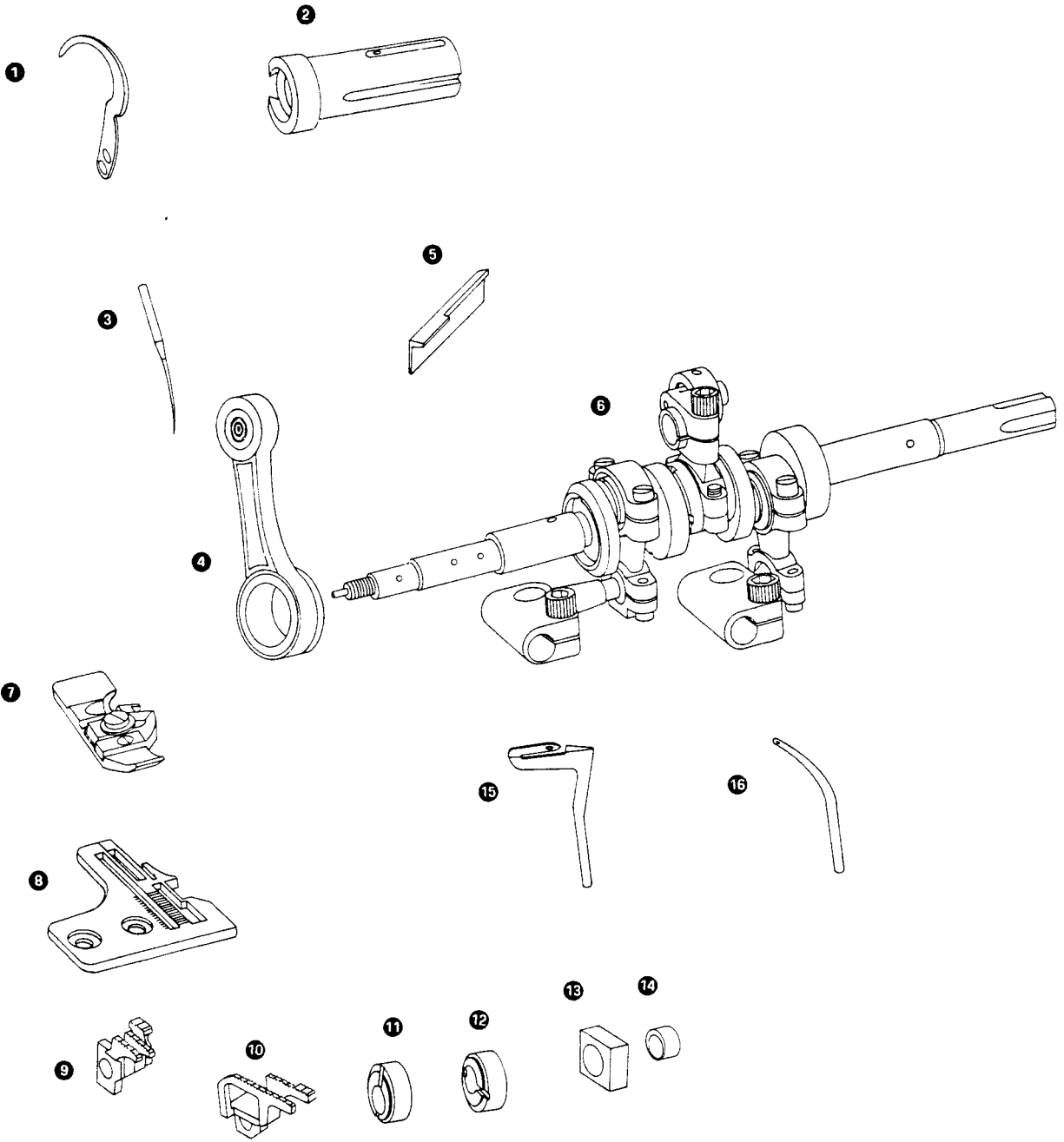

**ACCESSORIES
SUPPLIED WITH MACHINE**



AVAILABLE AT AN EXTRA CHARGE

